

CH310 / CH270

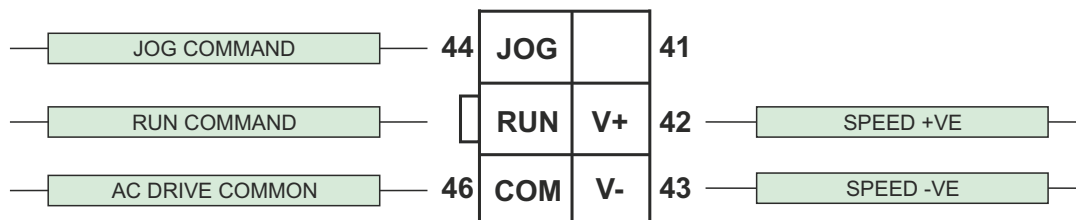

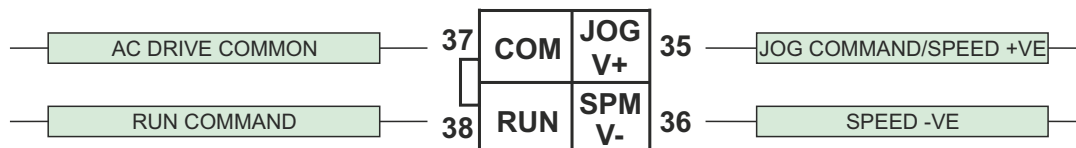

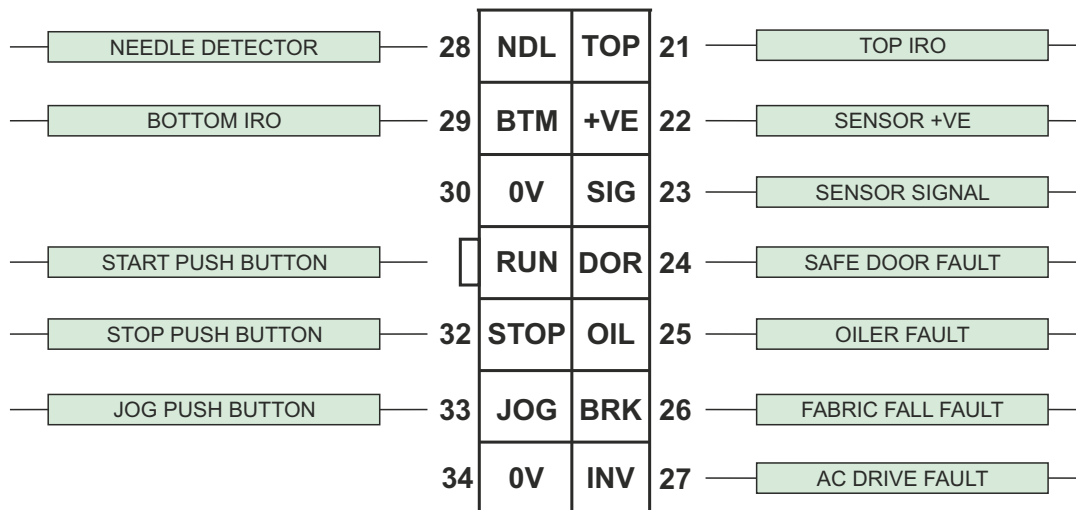

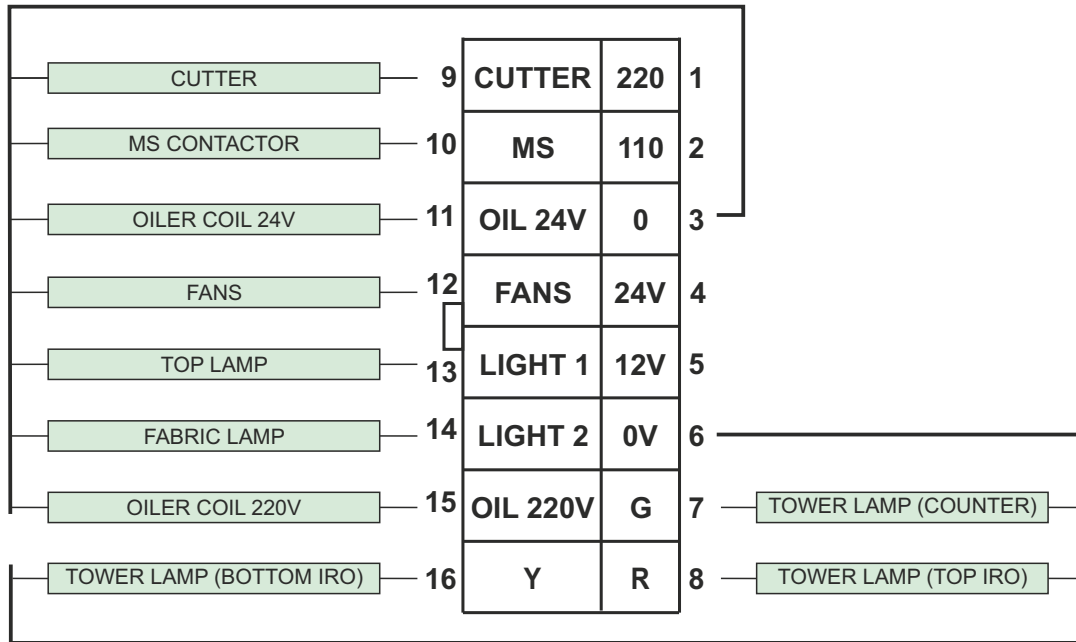
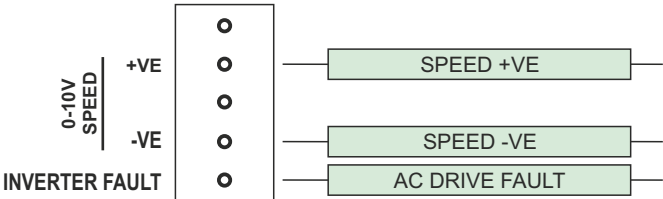
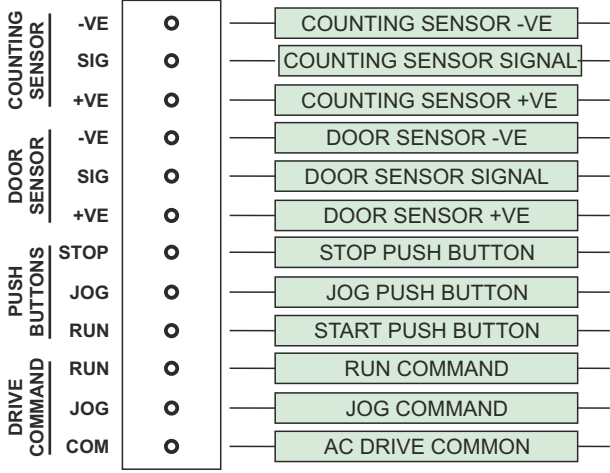
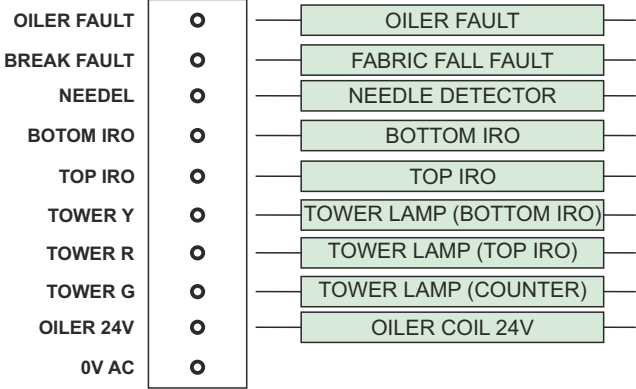
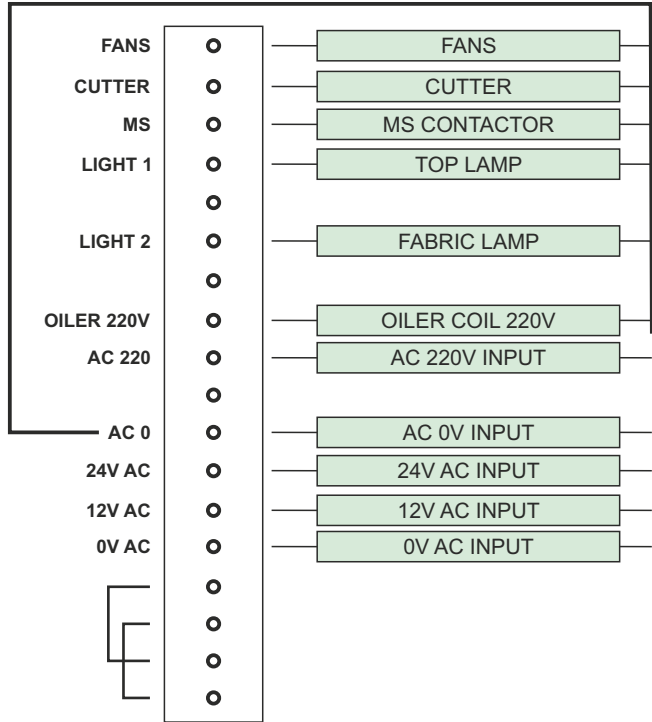







WHITE CONNECTOR DETAILS



GREEN CONNECTOR DETAILS



OPERATION MANUAL

- ★ To reset current counter value to 0, press  button only when machine is stopped.
- ★ To enter in the TOTAL display mode, press  button. Now see the WHOLE TOTAL counter value or TOTAL valve of A, B & C shift by pressing  button again & again. If to reset the total value of A, B or C shift to 0, press  button after displaying its value.
- ★ To come to the normal display mode, press  button. Note that WHOLE TOTAL counter can not be reset to 0.
- ★ To FLUSH the oil, when machine is stopped, press and hold  &  buttons together.
- ★ To switch ON the FANS when machine is stopped, make the MOTOR button OFF, then press  button to start the FANS and press  button to stop them.
- ★ To display the no. of total FABRIC ROLLS produced, press  &  buttons together. If to reset the ROLL value, press  button. Press  &  again to exit.

HOW TO ENTER VARIOUS DISPLAY & SETTING MODES :

- ★ Press & Hold  button to enter the setting modes as SET, StP CAUSE, no/nc StoP, YES/no OPEn2, no/nc door and YES/no rStd.

NOTE : Leave the SET button when desired setting mode displayed, make changes as needed, then press  button to exit the setting modes and to save the new setting.

Display Mode

Explanation of Display Modes







StP CAUSE

In this mode, controller will show the reason of last machine stop by glowing its led e.g TOP, BOTTOM or NEEDLE etc.

Setting Mode

Default Setting

Explanation of Setting Modes

SET	5	Set the desired Counter Value by pressing  &  buttons.
no/nc StoP	no	Change to 'nc' by pressing  button, if to use NC STOP push buttons.
YES/no OPEn2	YES	Change to 'no' by pressing  button if not to use OPEN 2 function at all.
no/nc door	nc	Change to 'no' by pressing  button if to use NO Safe Door Switches.
YES/no rStd	no	Change to 'YES' by pressing  button if to use RESET type needle detectors. Also change the jumper to YES (near the 1N5408 diodes in the back card), to activate the function.

JUMPER SETTINGS

DEFAULT JUMPER SETTING (Relay Card)

Oiler Coil	- Voltage Output	(Change both jumpers if relay output required)
Speed Change	- From Panel	(Change if Speed to be changed from AC DRIVE)

SPECIFICATIONS

- * Panel Size : CH310 ----- 310 x 230 mm or 12.25 x 9 inch.
CH270 ----- 270 x 210 mm or 10.63 x 8.27 inch.
- * Panel Cutout Size : 245 x 190 mm or 9.65 x 7.48 inch for both CH310 and CH270 models.
- * Body Type : Metal body (fabricated using CNC technology and powder coating).
- * Fully automatic Micro-Controller based design.
- * A, B, C Shift Counter upto 65000.
- * Counter Range : 0 to 99999.
- * R.P.M. Range : 0 to 99.9 R.P.M.
- * WHOLE TOTAL Counter Range : 0 to 9,99,99,999.
- * FABRIC ROLL Counter Range : 0 to 65000.
- * STOP Push Buttons : NO / NC (Programmable).
- * SAFE DOOR : NO / NC (Programmable).
- * Working of OPEN2 mode YES/NO (Programmable).
- * Display of the last reason of machine stop.
- * Display : Red colour 7-Segment display.
- * Machine Speed Change : From Panel Box / From AC Drive (Selectable).
- * Oiler Coil : Voltage Output / Contact Output (Selectable).
- * User Interface : Easy & Simple operation.
- * Machine Compatibility : Both WHITE and GREEN Plugs wiring.

PROTECTION FEATURES

Protection against IRO Wire Short Circuit : Unlike China Panels, If TOP, BOTTOM, or NEEDLE DETECTOR wire directly touches the machine body, no internal circuit damage will happen to the panel board. Moreover panel board will show the IRO SHORT indication and also which IRO wire has touched the machine body.

Protection against Counting Sensor Short Circuit : Unlike China Panels, if the COUNTING or SAFE DOOR sensor's +VE and -VE wires are shorted together or the sensor itself gets short circuit, by any reason, no internal circuit damage will happen to the panel board.

Machine Speed Jerk Protection (Mechanically) : Panel board will gradually decrease the machine speed to 1/4 of the running speed in last 2 rounds before roll completion rather than suddenly turning the speed to JOG SPEED or stopping the machine with jerk, after roll completion, avoiding mechanical jerks.

AC Drive Protection : When the machine is running, the motor cannot be turned OFF directly even by pressing the motor switch to prevent damage to the AC drive caused by sudden voltage drop. Motor switch will work only when machine is stopped.

MACHINE ACCIDENT PREVENTION

Needle Damage Protection Features

You can save a significant amount of your money and time by avoiding major financial losses and downtime caused by common machine accidents in the knitting industry, through our control panels.

1. When the RUN Push Button gets stuck or becomes direct :

Our panel automatically stops the machine after 2-seconds if the any run push button gets stuck or becomes direct after pressing. It also shows a continuous indication on the display by showing 'RUN BUTTON'. This unique feature helps prevent machine accidents caused by following situations :-

Human Accident Case 1 :

If any run push button gets stuck or becomes direct after pressing, there won't be any indication on other panels to alert about this issue. Consequently, if machine stops due to yarn break or the operator stops the machine by activating a TOP or BOTTOM IRO for roll cutting (a common practice) or to perform other task under the winder section of the machine. However, at this time, if IRO becomes inactive by any reason, machine will start running automatically due to the stuck run push button. This situation could result in severe injury or even death.

Human Accident Case 2 :

Many operators directly open the safe door, knowing that the machine will stop automatically. However, if the run push button is stuck, the machine may stop initially when the gate is opened. But if the safe door get closed by any reason while the operator is inside the winder section, machine will start running automatically, This situation could result in severe injury or even death.

Machine Accident Case :

If the run push button gets stuck or becomes direct after pressing, there won't be any indication on other panels to alert about the issue. Consequently, if the operator stops the machine by activating a TOP or BOTTOM IRO (a common practice) to change a needle by dismantling a cam. However, at this time, if IRO becomes inactive by any reason, machine will start running automatically due to the stuck run push button. This could lead to the machine mechanical accident and a major needle damage and financial loss.

2. When the JOG Push Button gets stuck or becomes direct :

Specially when the machine is running in OPEN 2 mode, while jogging, if any jog button gets stuck or becomes direct, even if the operator does not pay attention, our panel will still stop the machine when yarn breaks. Other panels keep the machine jogging. This could damage the needles due to the loose fabric produced resulting the financial loss and time wastage.

3. Accident Prevention from Motor Switch :

While the machine is under mechanical maintenance or the CAMS are opened for NEEDLE change, operators generally switch OFF the MOTOR SWITCH from the panel board. At this time, if any jog or run push button have got stuck or became direct and someone, even by mistake, press the MOTOR SWITCH e.g. when trying to clean the panel board or by any other mistake, the MOTOR SWITCH will not work until the stuck button is fixed. This prevents human accidents & NEEDLE damage since the machine can't be START until is fully ready to run.

PREMIUM FEATURES OVER CHINA PANELS

AC Drive Error Handling : When there's an error in the AC Drive, machine stops suddenly and the AC Drive shuts off before you can see the error. With our panel, the machine stops quickly in case of an AC Drive error, but it waits 10 seconds before turning off the drive. This gives you time to read the error and arrange for repairs.

Power Saving Feature : Side lamps are automatically turned ON when the door is opened for fabric roll cutting and off when the door is closed, eliminating the need to keep them ON continuously.

Total Fabric Roll Counting : Now you don't have to count the fabric rolls manually, our panel will count the total number of fabric rolls produced and will display it to help you track production.

RESET Button Lock : The reset button is automatically locked while the machine is running or jogging to prevent accidental counter resets.

Displays The Reason of Machine Stoppage : Our panel shows the last reason of machine stoppage. Specially in case of vibrating IRO's, when machine stops again and again without any indication, the reason of stoppage can be displayed to quickly identify issues without wasting the time and boosting the production.

Push Button Indication on Display : If JOG, RUN, or STOP push button is pressed, stuck, or becomes direct, it will be displayed on the display. Unlike other panels that lack this feature, our display immediately alerts the machine operator or electrician about the issue. This saves time and increase production by eliminating the need to check every aspect of the machine to identify the problem.

Roll Completion Indication : Roll completion status is also displayed on the display.

Stop Buttons NO/NC Setting : STOP push buttons type (NO/NC) can be configured via the setting, eliminating the need to change machine's wiring. Simply go to settings and select the STOP push button type as NO or NC.

OPEN 2 Function Setting : If not needed at all, OPEN 2 function can be deactivated via the setting, Simply go to settings and select the OPEN 2 as no.

Safe Door NO/NC Setting : Safe Door type (NO/NC) can be configured via the setting, eliminating the need to change machine's wiring. Simply go to settings and select the Safe Door type as NO or NC.

Switch Protection : If TOP LAMP, FAB LAMP, or FAN switches were ON before a power failure, they will automatically be switched ON with a small delay upon power restoration, increasing the life span of switches.

Reset Switch Protection : When a fabric roll completes, the counter can be reset from the panel's reset switch or by pressing any STOP and RUN push buttons together, increasing the life span of the RST switch.

NOTE : Counter will not get reset from STOP and RUN push buttons, before the completion of the fabric roll.

OPEN 1 Option : The OPEN 1 function works from the COMPEL switch or by pressing the JOG and STOP push buttons together, while jogging.

BENEFITS

Say goodbye to unreliable Chinese Panels. Upgrade to Panels with cutting edge technology.

- * Premium quality and exceptional reliability.
- * Unique features to boost your machine's productivity.
- * Exclusive accident protection and prevention features not offered by any other panel board.
- * Fabric roll counting features to help you keep record.
- * Power saving and short- circuit protection features.
- * The most affordable price range in the market.
- * A durable life span with complete local repairability.
- * A simple and straight forward installation process for user convenience.
- * Custom features provided at lower prices based on your requirements and budget.
- * Compatibility with all brands and all types of circular knitting machines.